

TYPICAL DOOR LOCATION DETAIL
 **HORIZONTAL RUNNING CLEARANCES AS REQUIRED BY ASME A17.1, SECTION 5.3

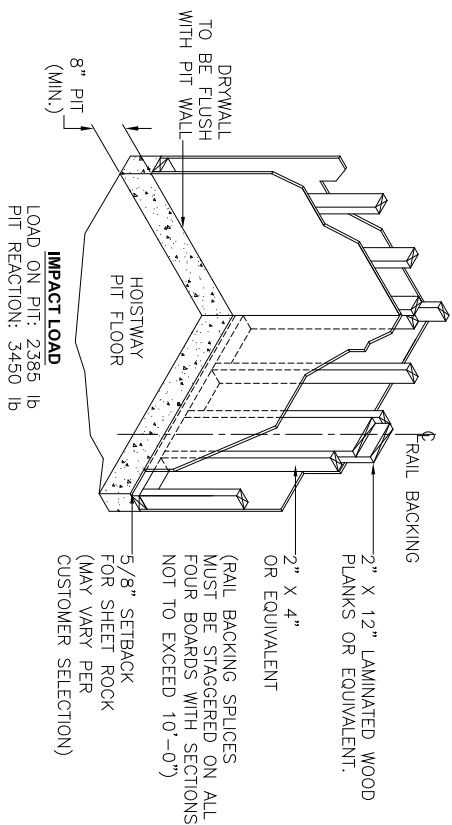

NOTE: A PLUMB HOISTWAY WITH A TOLERANCE NO LESS THAN 1/4" IN 20'-0" IS REQUIRED. THE HOISTWAY RAIL MOUNTING WALL AND THE LANDING MUST BE PERPENDICULAR TO MAINTAIN CODE REQUIRED RUNNING CLEARANCES. THE PIT FLOOR MUST BE SMOOTH, LEVEL AND AT THE PROPER DEPTH.

DRAWING TITLE: **HOISTWAY PLAN VIEW**
 DEALER NAME: **36 X 48 90° OPENING**
 JOB NAME:
 JOB NO.:
 DRAWING NO.: **HWY3648-101 9LR**
 DATE: **03/07/08**
 SCALE: **NTS**
 SHEET: **1** OF: **1**

TYPICAL DRAWING
 PROPRIETARY AND CONFIDENTIAL
 THE INFORMATION CONTAINED IN THIS DRAWING IS THE SOLE PROPERTY OF ADVANTAGE HOME ELEVATOR. ANY REPRODUCTION IN PART OR AS A WHOLE WITHOUT THE WRITTEN CONSENT OF ADVANTAGE HOME ELEVATOR IS PROHIBITED.

RELEASE SIGNATURE
 DRAWN BY: **ESANCHEZ**
 CHECKED BY: **DBROWN**
 ENG. APP: **DBROWN**
 DESIGN APP:
 Q.C. APP:

REV	ECN	DESCRIPTION	DRAWN BY	DATE	CHECKED BY
REVISIONS					

FOR DEALER USE ONLY:
 OWNER/CONTRACTOR: _____ DATE: _____
 ALL DIMENSIONS HAVE BEEN DERIVED FROM THE ADVANTAGE ORDER FORM. ACTUAL SITE CONDITIONS MAY VARY FROM THE DRAWING. ADVANTAGE HOME ELEVATOR SHALL NOT BE RESPONSIBLE FOR ANY DISCREPANCIES OR TOLERANCES ARE SET TO INDUSTRY AND NATIONAL CODE STANDARDS UNLESS OTHERWISE NOTED, AND ARE SUBJECT TO CHANGE WITHOUT NOTICE. PLEASE CHECK THE APPROPRIATE ACTION BOX AND RETURN TO THE ADVANTAGE CUSTOMER SERVICE DEPARTMENT.
 APPROVED AS NOTED
 CHANGES AND REAPPROVAL ARE REQUIRED
 SIGNATURE _____ DATE _____

ADVANTAGE HOME ELEVATOR ELEVATOR EQUIPMENT CORP.
 4056 GORDMAN AVE. LOS ANGELES, CA 90034
 2230 N.W. 12TH STREET RICHMOND, IN 47374
 PHONE: (888) 877-4762
 FAX: (323) 762-1780

"NOT FOR CONSTRUCTION"
 TYPICAL HOISTWAY DRAWINGS, "AS DRAWN" ARE FOR GENERAL CONFORMANCE WITH ADVANTAGE'S MINIMUM REQUIREMENTS ONLY. PLEASE GET IN TOUCH WITH AHE FOR DESIGN SUPPORT, AND/OR JOB SPECIFIC DRAWINGS. FINAL PROJECT APPROVAL DRAWINGS FROM ADVANTAGE ARE REQUIRED BEFORE BEGINNING HOISTWAY CONSTRUCTION.