

**"NOT FOR CONSTRUCTION"**

\*\*TYPICAL HOISTWAY DRAWINGS, "AS DRAWN" ARE FOR GENERAL CONFORMANCE WITH ADVANTAGE'S MINIMUM REQUIREMENTS ONLY. PLEASE GET IN TOUCH WITH AHE FOR DESIGN SUPPORT, AND/OR JOB SPECIFIC DRAWINGS. FINAL PROJECT APPROVAL DRAWINGS FROM ADVANTAGE ARE REQUIRED BEFORE BEGINNING HOISTWAY CONSTRUCTION.\*\*

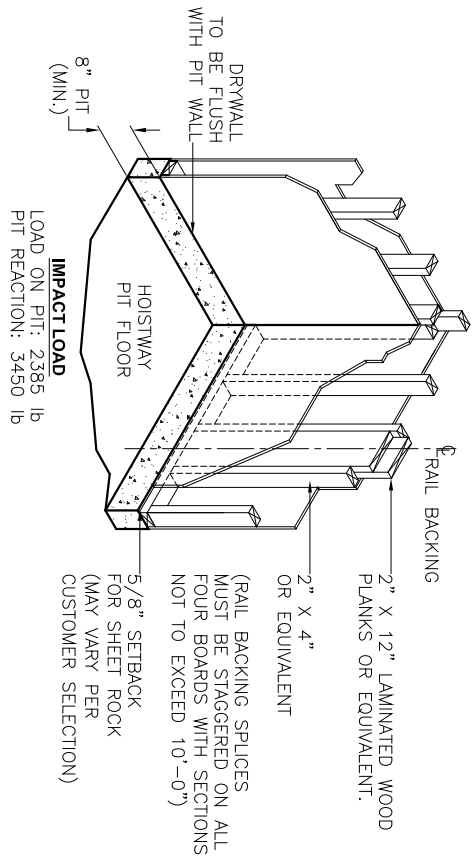

NOTE: A PLUMB HOISTWAY WITH A TOLERANCE NO LESS THAN 1/4" IN 20'-0" IS REQUIRED. THE HOISTWAY RAIL MOUNTING WALL AND THE LANDING MUST BE PERPENDICULAR TO MAINTAIN CODE REQUIRED RUNNING CLEARANCES. THE PIT FLOOR MUST BE SMOOTH, LEVEL AND AT THE PROPER DEPTH.

DRAWING TITLE: **HOISTWAY PLAN VIEW**  
 48 X 36 FRONT RAIL OPENING

DEALER NAME:

JOB NAME:

JOB NO.:

DRAWING NO.: **HWY3648-101 IOL**

DATE: **03/07/08**

SCALE: **NTS**

SHEET: **1** OF: **1**

**TYPICAL DRAWING**

**PROPRIETARY AND CONFIDENTIAL**

THE INFORMATION CONTAINED IN THIS DRAWING IS THE SOLE PROPERTY OF ADVANTAGE HOME ELEVATOR. ANY REPRODUCTION IN PART OR AS A WHOLE WITHOUT THE WRITTEN CONSENT OF ADVANTAGE HOME ELEVATOR IS PROHIBITED.

RELEASE SIGNATURE

DATE

DRAWN BY: **ESANCHEZ**

CHECKED BY: **DBROWN**

ENG. APP: **DBROWN**

DESIGN APP:

Q.C. APP:

FOR DEALER USE ONLY:

OWNER/CONTRACTOR:

DATE:

ALL DIMENSIONS HAVE BEEN DERIVED FROM THE ADVANTAGE ORDER FORM. ACTUAL SITE CONDITIONS MAY VARY FROM THE ORDER. ADVANTAGE HOME ELEVATOR SHALL NOT BE RESPONSIBLE FOR ANY DISCREPANCIES OR MANUFACTURING TOLERANCES ARE SET TO INDUSTRY AND NATIONAL CODE STANDARDS UNLESS OTHERWISE NOTED, AND ARE SUBJECT TO CHANGE WITHOUT NOTICE. PLEASE CHECK THE APPROPRIATE ACTION BOX AND RETURN TO THE ADVANTAGE CUSTOMER SERVICE DEPARTMENT.

APPROVED WITH NO EXCEPTIONS

APPROVED AS NOTED

CHANGES AND REAPPROVAL ARE REQUIRED

SIGNATURE: \_\_\_\_\_ DATE: \_\_\_\_\_

**ADVANTAGE HOME ELEVATOR ELEVATOR EQUIPMENT CORP.**

4056 GORDMAN AVE. LOS ANGELES, CA 90029  
 2230 N.W. 12TH STREET RICHMOND, IN 47374

PHONE: (888) 877-4762  
 FAX: (323) 762-1780

REV	ECN	DESCRIPTION	DRAWN BY	DATE	CHECKED BY
<b>REVISIONS</b>					