

HOISTWAY PLAN VIEW

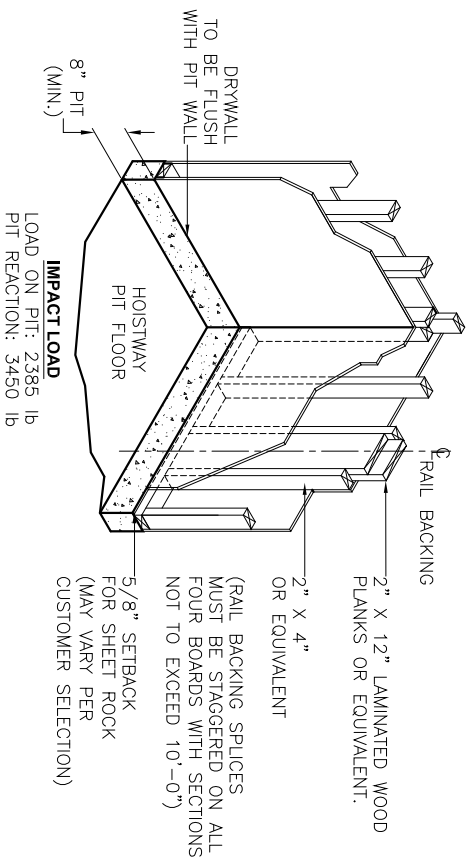
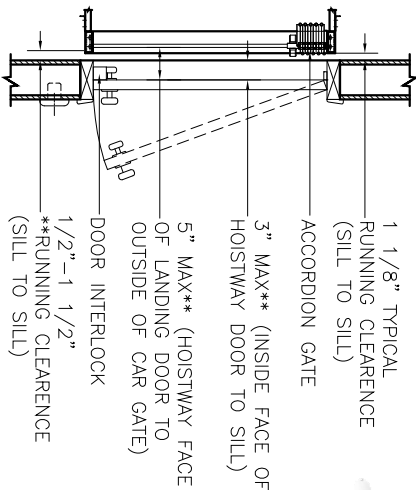
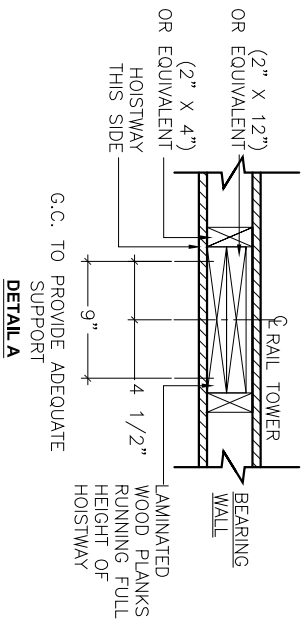

NOTE: A PLUMB HOISTWAY WITH A TOLERANCE NO LESS THAN 1/4" IN 20'-0" IS REQUIRED. THE HOISTWAY RAIL MOUNTING WALL AND THE LANDING MUST BE PERPENDICULAR TO MAINTAIN CODE REQUIRED RUNNING CLEARANCES. THE PIT FLOOR MUST BE SMOOTH, LEVEL AND AT THE PROPER DEPTH.

DRAWING TITLE: **HOISTWAY PLAN VIEW**

DEALER NAME: **36 X 48 IN LINE OPENING**

JOB NAME:

JOB NO.:

DRAWING NO.: **HWY3648-101 IRL**

DATE: **03/07/08**

SCALE: **NTS**

TYPICAL DRAWING

PROPRIETARY AND CONFIDENTIAL
THE INFORMATION CONTAINED IN THIS DRAWING IS THE SOLE PROPERTY OF ADVANTAGE HOME ELEVATOR. ANY REPRODUCTION IN PART OR AS A WHOLE WITHOUT THE WRITTEN CONSENT OF ADVANTAGE HOME ELEVATOR IS PROHIBITED.

RELEASE SIGNATURE

DRAWN BY: **ESANCHEZ**

CHECKED BY: **D.BROWN**

ENG. APP: **D.BROWN**

DESIGN APP:

Q.C. APP:

REVISIONS

FOR DEALER USE ONLY:
OWNER/CONTRACTOR: _____ DATE: _____

REVISIONS

DATE: _____

ALL DIMENSIONS HAVE BEEN DERIVED FROM THE ADVANTAGE ORDER FORM. ACTUAL SITE CONDITIONS MAY VARY FROM THE ORDER. ALL DIMENSIONS MUST BE VERIFIED PRIOR TO ORDER. PLANS ARE THE PROPERTY OF ADVANTAGE HOME ELEVATOR. TOLERANCES ARE SET TO INDUSTRY AND NATIONAL CODE STANDARDS UNLESS OTHERWISE NOTED, AND ARE SUBJECT TO CHANGE WITHOUT NOTICE. PLEASE CHECK THE APPROPRIATE ACTION BOX AND RETURN TO THE ADVANTAGE CUSTOMER SERVICE DEPARTMENT.
 APPROVED WITH NO EXCEPTIONS
 APPROVED AS NOTED
 CHANGES AND REAPPROVAL ARE REQUIRED
SIGNATURE _____ DATE _____

ADVANTAGE HOME ELEVATOR ELEVATOR EQUIPMENT CORP.
4036 GORDMAN AVE. LOS ANGELES, CA 90039
2230 N.W. 12TH STREET, RICHMOND, IN 47374
PHONE: (888) 877-4762
FAX: (323) 762-1780

"NOT FOR CONSTRUCTION"
TYPICAL HOISTWAY DRAWINGS, "AS DRAWN" ARE FOR GENERAL CONFORMANCE WITH ADVANTAGE'S MINIMUM REQUIREMENTS ONLY. PLEASE GET IN TOUCH WITH A/E FOR DESIGN SUPPORT, AND/OR JOB SPECIFIC DRAWINGS. FINAL PROJECT APPROVAL DRAWINGS FROM ADVANTAGE ARE REQUIRED BEFORE BEGINNING HOISTWAY CONSTRUCTION.